



SCHEMA DI MONTAGGIO ZPSC4

ZANZARIERA SCORREVOLE

APERTURA MANUALE

QUATTRO ANTE

DISTINTA

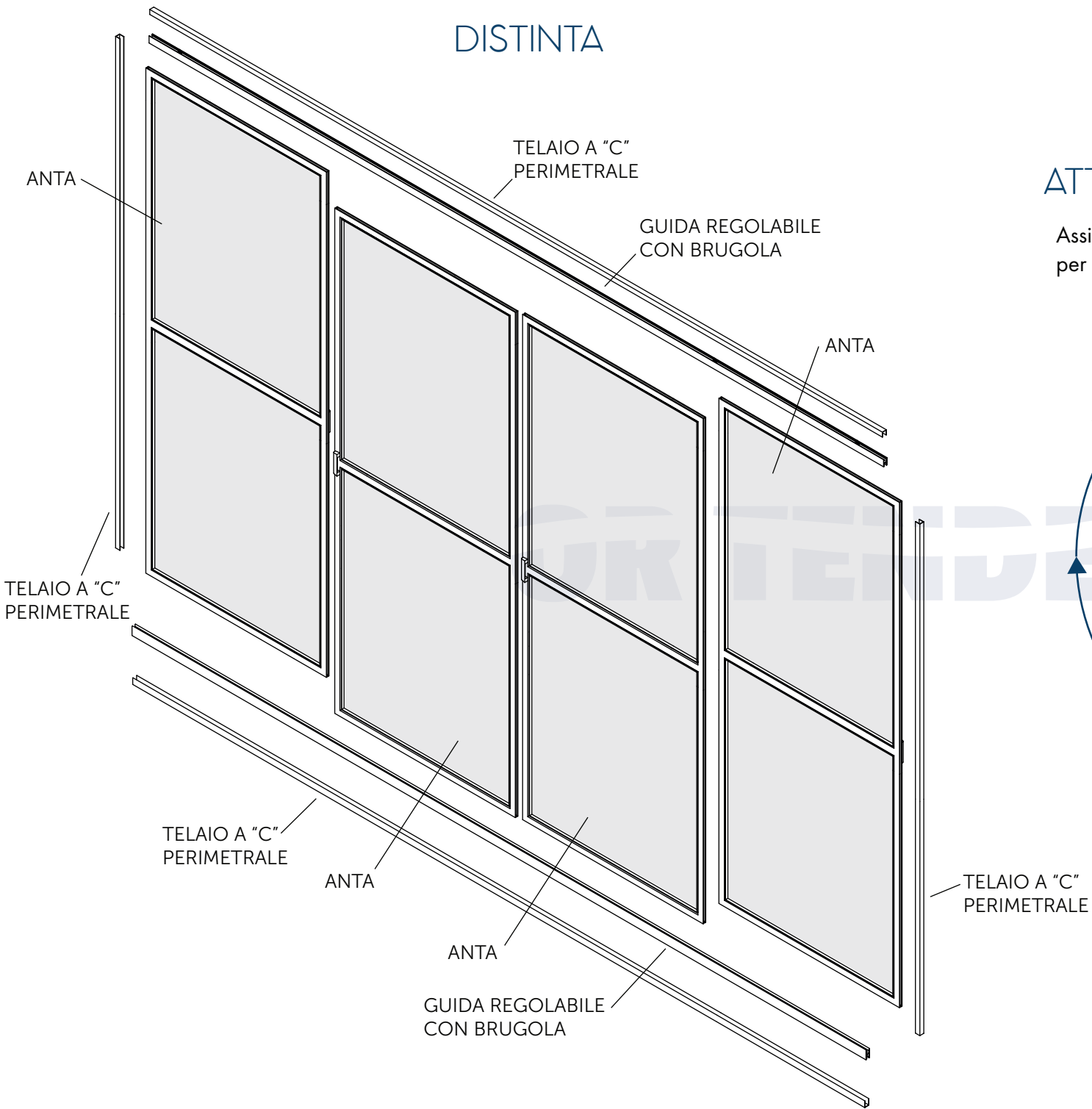

ATTREZZI PER IL MONTAGGIO

Assicurarsi di avere con se tutto lo stretto necessario per un comodo e sicuro montaggio.

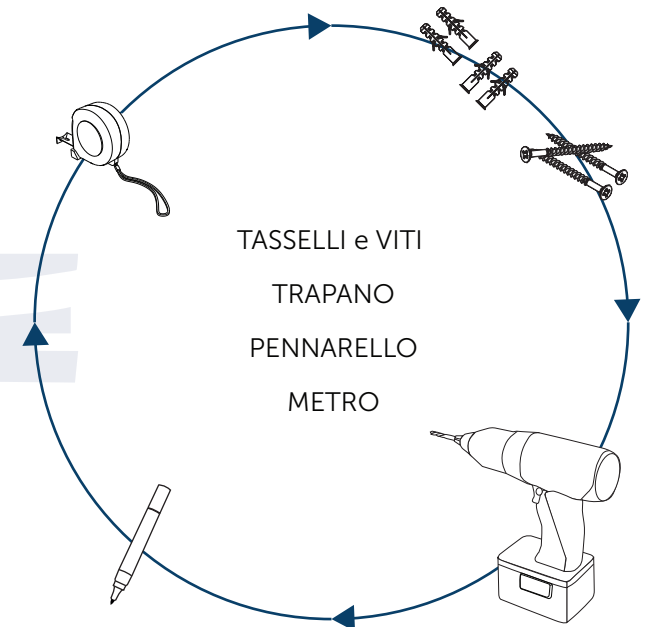

INSTALLAZIONE DEI TELAI A C VERTICALI

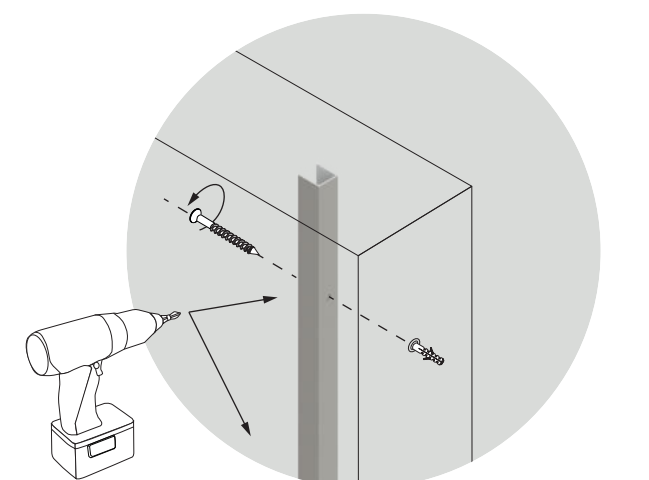
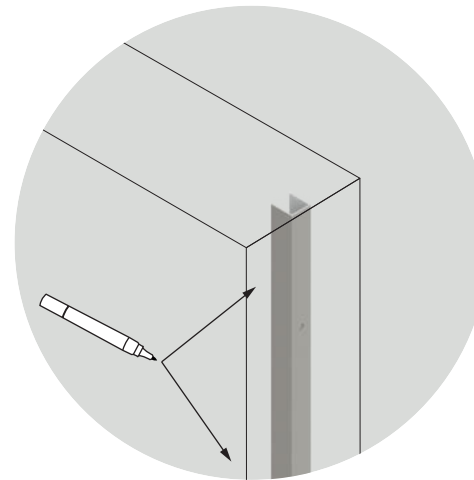
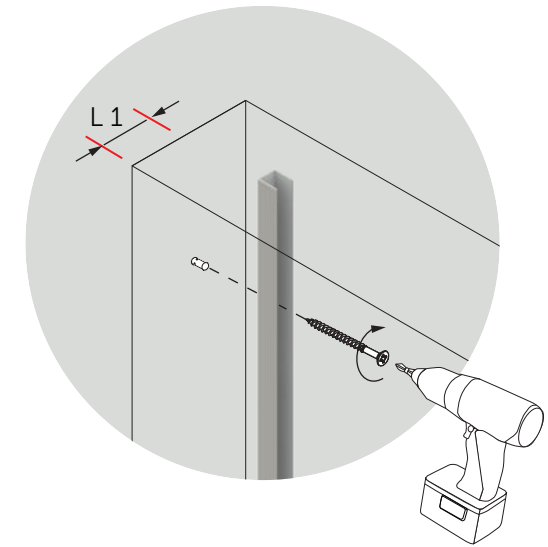
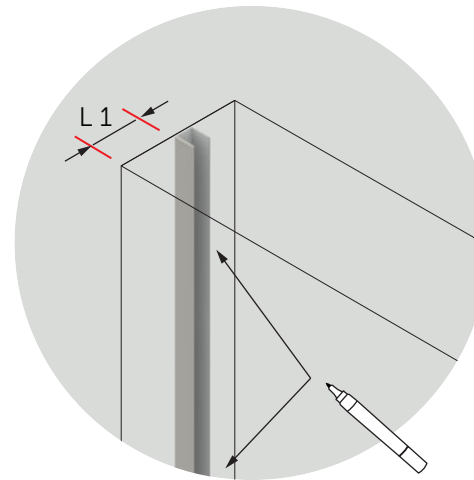
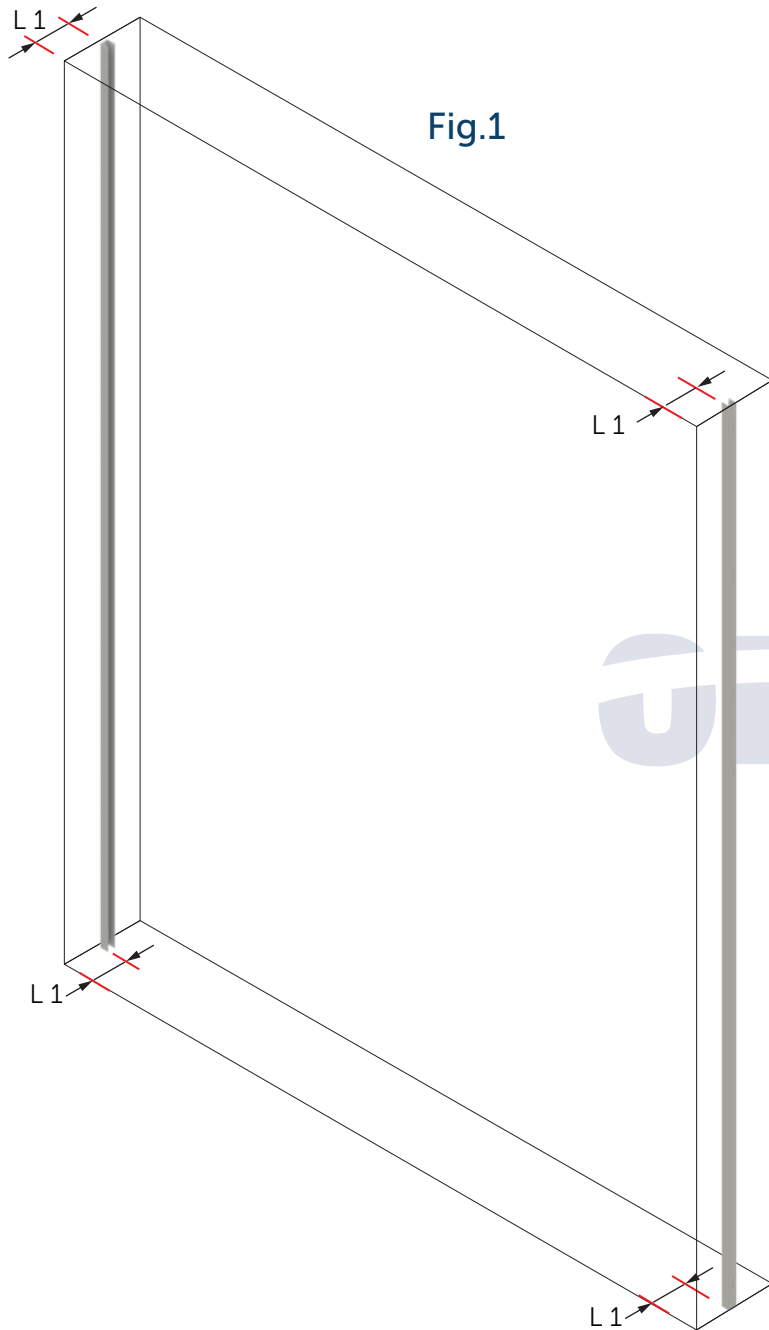

Posiziona i telai a C verticali e assicura il parallelismo L1 (Fig 1 , 2 e 4). Segna i punti con un pennarello in corrispondenza dei fori del telaio di sinistra (Fig 2). Esegui i fori e fissalo con i tasselli (Fig 3). Esegui gli stessi passaggi per il telaio a C a destra (Fig 4 e 5).

INSTALLAZIONE DEI TELAI A C ORIZZONTALI

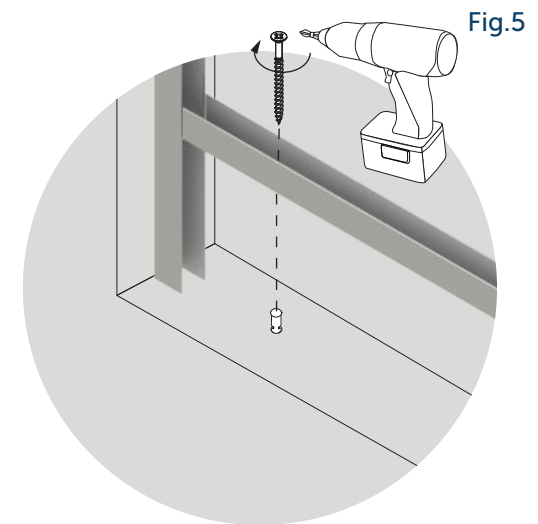
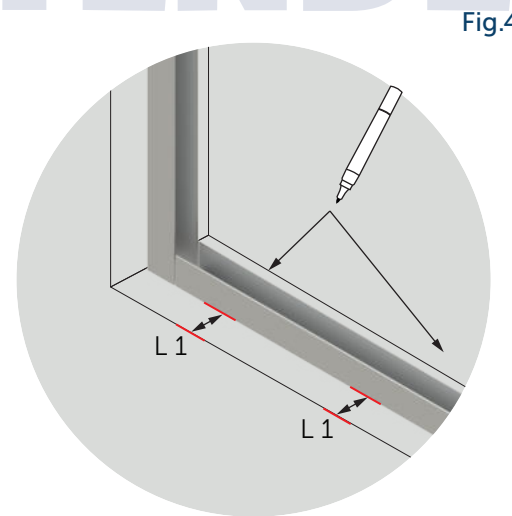
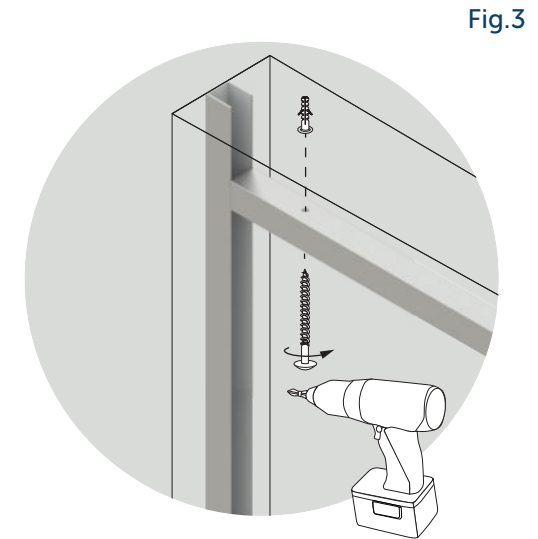
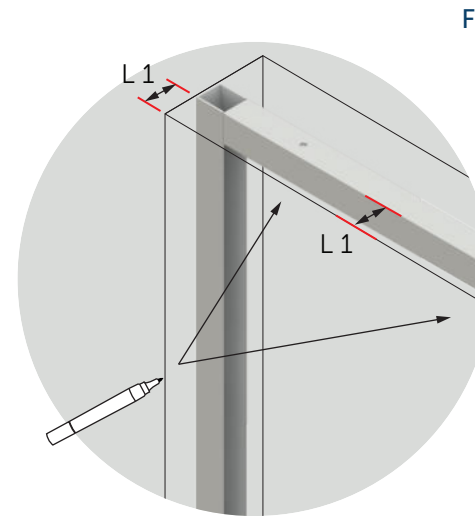
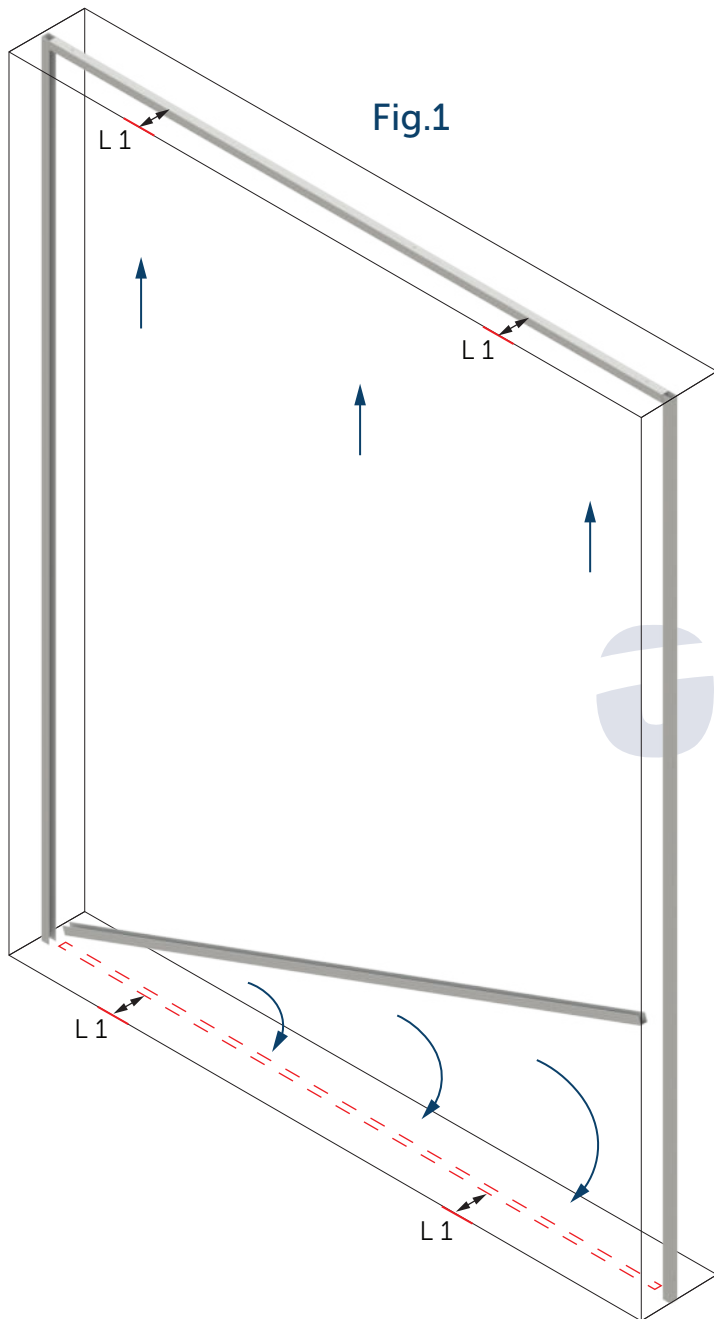

Posiziona i telai a C orizzontali e assicura il parallelismo L1 (Fig 1 , 2 e 4). Segna i punti con un pennarello in corrispondenza dei fori del telaio superiore (Fig 2). Esegui i fori e fissalo con i tasselli (Fig 3). Esegui gli stessi passaggi per il telaio a C inferiore (Fig 4 e 5).

INSTALLAZIONE GUIDE REGOLABILI CON BRUGOLA

Fig.1

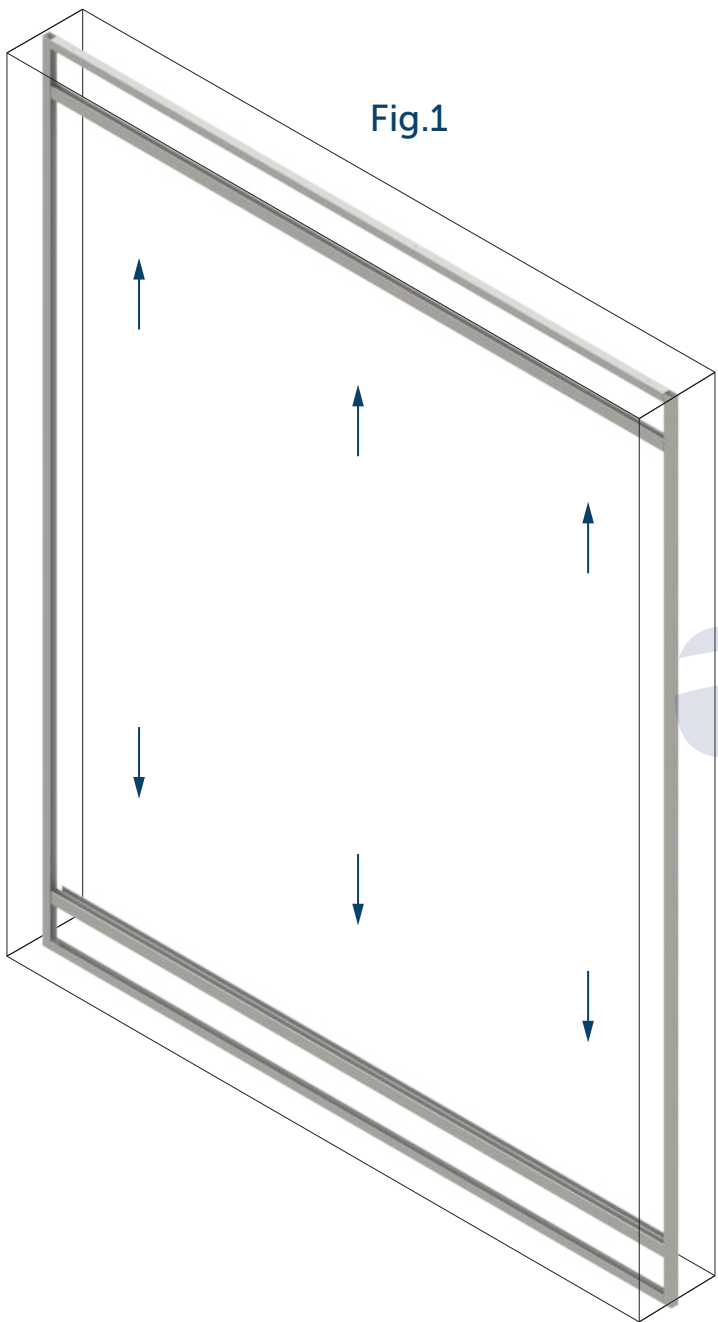

Fig.2

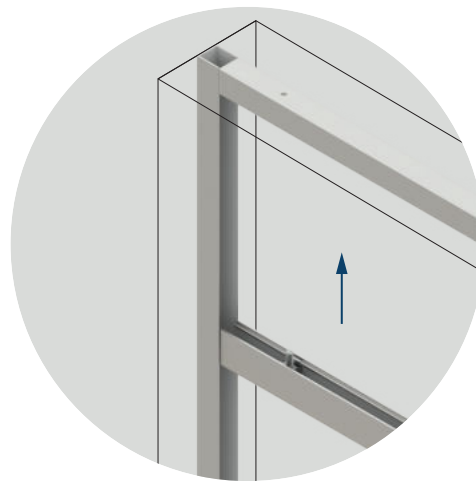

Fig.3



Fig.4

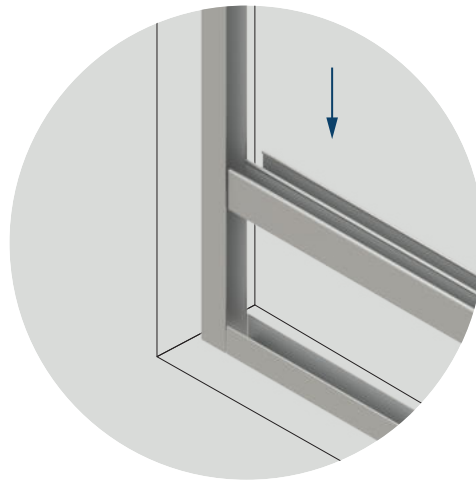

Fig.5



Inserisci le guide regolabili in alto e in basso all'interno della guida a C (Fig 1, 2 e 4).

INSTALLAZIONE DELLE ANTE

Fig.1

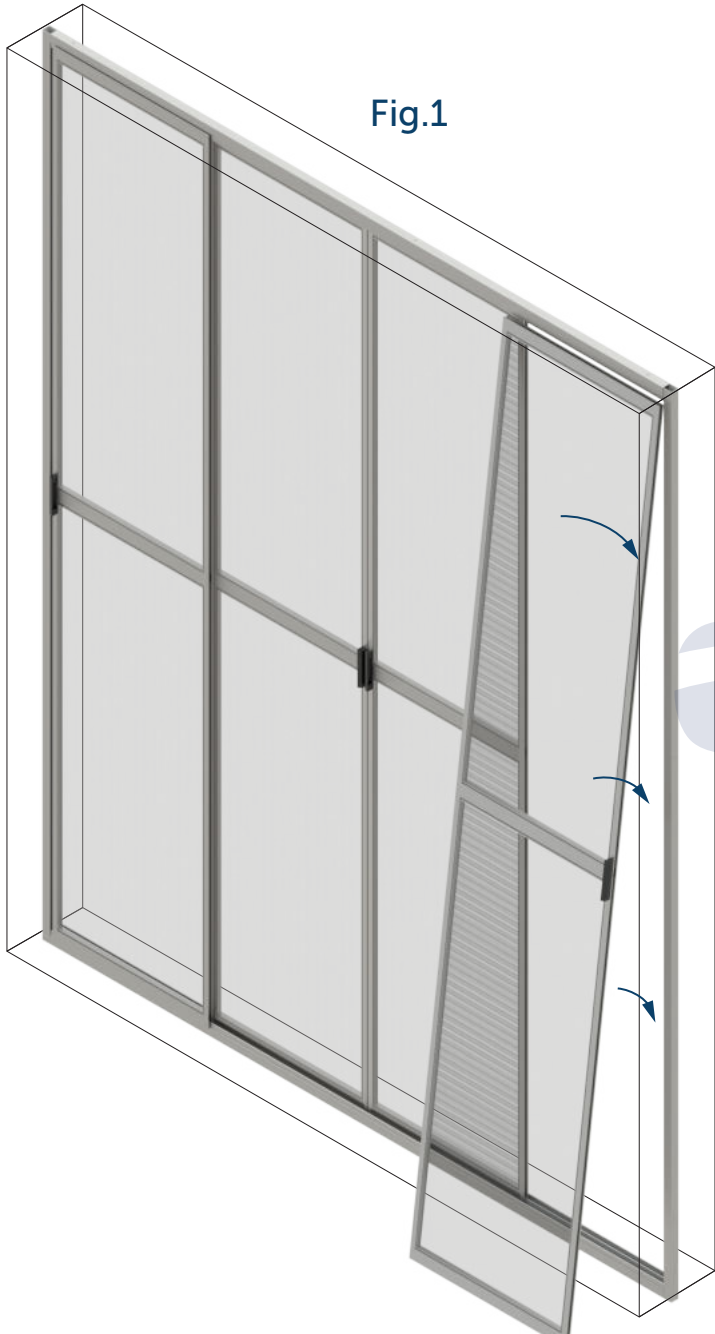

Fig.2



Fig.3



Fig.4



Fig.5



Inserisci la parte superiore dell'anta dove all'interno sono presenti delle molle nella guida regolabile superiore (Fig 1 e 2). Fai pressione con le molle in alto e appoggia la parte inferiore dell'anta con le carrucole nella guida regolabile inferiore (Fig 4). Regola l'altezza delle ante con le viti a brugola installate nelle guide regolabili (Fig 5).